



DIESEL GENERATOR SET

| SERVICE | | STAND BY | PRIME |
|------------------|---------|----------|-------|
| Power | kVA | 725 | 659 |
| Power | kW | 580 | 527,2 |
| Speed | r.p.m | 1500 | |
| Standart Voltage | V | 400/231 | |
| Power Factor | Cos Phi | 0,8 | |

Prime Power (PRP)

According to ISO 8528-1:2005, Prime power is the maximum power which a generating set is capable of delivering continuously whilst supplying a variable electrical load when operated for an unlimited number of hours per year under the agreed operating conditions with the maintenance intervals and procedures being carried out as prescribed by the manufacturer. The permissible average power output (Ppp) over 24 h of operation shall not exceed 70 % of the PRP.

Emergency Standby Power (ESP):

According to ISO 8528-1:2005, Emergency standby power is the maximum power available during a variable electrical power sequence, under the stated operating conditions, for which a generating set is capable of delivering in the event of a utility power outage or under test conditions for up to 200 h of operation per year with the maintenance intervals and procedures being carried out as prescribed by the manufacturers. The permissible average power output over 24 h of operation shall not exceed 70 % of the ESP.



+90 533 070 09 09 pbx
info@thorgenerator.com

THOR GENERATOR

High E Blok Daire 3106 Ünalın Mah. Libadiye Cad.

Emaar Squar Üsküdar/İstanbul/Türkiye

+90 216 759 81 29 | www.thorgenerator.com

ENGINE

SPECIFICATIONS

| | | |
|-------------------------------|------------|-------------------|
| Brand | | PERKINS |
| Model | | 2806AE18TAG2 |
| Engine Power | (kWm / hp) | 609/817 |
| Revolution Per Min | (r.p.m) | 1500 |
| Total Displacement | L | 18,1 |
| Cylinders Orientation | | 6 Vertical Inline |
| Bore x Stroke | mmxmm | 145 x 183 |
| Compression Orientation | | 14,5:1 |
| Governor Type | | Electronic |
| Aspiration System | | Turbo AAC |
| Injection | | Direct |
| Cooling | | Water Cooled |
| Electrical System (DC) | VDC | 24 |
| Lub-oil Capacity | lt | 62 |
| Engine Coolant Capacity | lt | 61 |
| Fuel Tank Capacity | lt | 800 |
| Maximum Exhaust Temperature | °C | 553 |
| Maximum Exhaust Gas Flow | m3/h | 114 |
| Maximum Allowed Back Pressure | kPa | 24 |
| Cooling Air Flow | m3/min | 702 |
| Fuel Consumption 50% | lt/h | 66 |
| Fuel Consumption 75% | lt/h | 97 |
| Fuel Consumption 100% | lt/h | 132 |

ALTERNATOR

SPECIFICATIONS

| | | |
|----------------------|--|--------|
| Number Of Phases | | 3 |
| Power Factor | | 0,8 |
| No of Bearings | | Single |
| No of Poles | | 4 |
| No of Leads | | 6-12 |
| Insulation Class | | H |
| Degree of Protection | | IP23 |
| Excitation System | | AVR |

DIMENSIONS

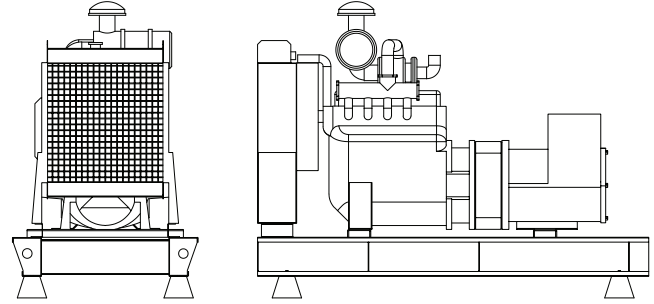

OPEN TYPE

| | | |
|--------------------|----|--------------------|
| WxLxH | mm | 1700 x 3700 x 2140 |
| Weight | kg | 4501 |
| Fuel Tank Capacity | lt | N/A |

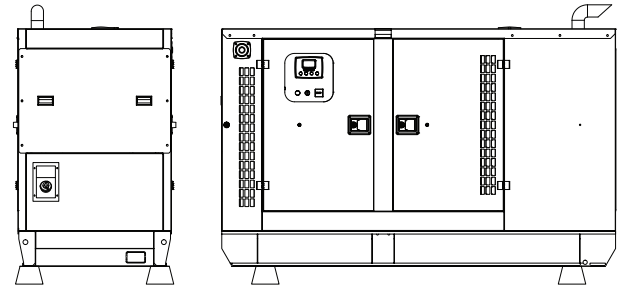

CANOIPIED

| | | |
|--------------------|----|--------------------|
| WxLxH | mm | 1700 x 4900 x 2730 |
| Weight | kg | 5406 |
| Fuel Tank Capacity | lt | N/A |

SOUNDPROOF CANOPIED

- Special design for minimizing acoustic level
- Galvanized steel construction further protected by polyester powder coat paint
- Black finish stainless steel locks and hinges
- Control panel viewing window in a lockable access door
- Emergency stop push button (red) mounted on enclosure exterior
- Lifting, drag and jacking points on base frame
- Radiator fill via removable, flush mounted rain cap fitted with compression seal



OPTIONAL GENSET CONTROLLERS

Next generation single gen-set controllers for Stand-by and Prime power applications combining multi-functionality and wide communication with EFI engines.

Datakom SMART 200



Datakom D500



Datakom D500-GSM



EMKO Trans-AUTO



DEEPSEA 7320



ComAp AMF25



| | Datakom SMART 200 | Datakom D500 | Datakom D500-GSM | Deepsea 6120 | Deepsea 7320 | ComAp AMF25 | EMKO Trans-AUTO |
|--|-------------------|--------------|------------------|--------------|--------------|-------------|-----------------|
| Automatic Mains Monitoring | ✓ | ✓ | ✓ | ✓ | ✓ | ✓ | ✓ |
| Manuel Start | ✓ | ✓ | ✓ | ✓ | ✓ | ✓ | ✓ |
| Remote Start | OPTIONAL | OPTIONAL | ✓ | X | OPTIONAL | OPTIONAL | OPTIONAL |
| Remote Monitoring With Sim Card | X | OPTIONAL | OPTIONAL | OPTIONAL | OPTIONAL | OPTIONAL | OPTIONAL |
| 1 Additional Option (Horn, Oil-Fuel Heater Etc.) | ✓ | ✓ | ✓ | ✓ | ✓ | ✓ | ✓ |
| Light Warning And Mimic Diagram | ✓ | ✓ | ✓ | ✓ | ✓ | ✓ | ✓ |
| Battery Charger | ✓ | ✓ | ✓ | ✓ | ✓ | ✓ | ✓ |
| Rs-485 Communication | OPTIONAL | ✓ | ✓ | X | ✓ | OPTIONAL | ✓ |
| Ethernet (Tcp-Ip) Communication | X | ✓ | ✓ | X | OPTIONAL | OPTIONAL | OPTIONAL |

OPTIONAL EQUIPMENTS

Some of our Optional Equipments which can be provided with Generator Sets But not limited to;

- Medium voltage alternator
- Remote radiator applications
- External fuel tanks. Automatic and Manuel fuel filling system from external fuel tanks
- Fuel tank heater, oil pan heater, Anti-condensation heater
- Alternator with PMG (Permanent Magnet Generator)
- Synchronization systems
- Double Walled Fuel Tanks
- Container type canopy
- Lube oil and fuel drain pumps
- Trailer
- Remote monitoring options on the control panel
- Electronic fuel level indicator

