



# THOR GENERATOR

## TG175C

## 50 Hz



## DIESEL GENERATOR SET

SERVICE		STAND BY	PRIME
Power	kVA	175	160
Power	kW	140	128
Speed	r.p.m	1500	
Standart Voltage	V	400/231	
Power Factor	Cos Phi	0,8	

### Prime Power (PRP)

According to ISO 8528-1:2005, Prime power is the maximum power which a generating set is capable of delivering continuously whilst supplying a variable electrical load when operated for an unlimited number of hours per year under the agreed operating conditions with the maintenance intervals and procedures being carried out as prescribed by the manufacturer. The permissible average power output (Ppp) over 24 h of operation shall not exceed 70 % of the PRP.

### Emergency Standby Power (ESP):

According to ISO 8528-1:2005, Emergency standby power is the maximum power available during a variable electrical power sequence, under the stated operating conditions, for which a generating set is capable of delivering in the event of a utility power outage or under test conditions for up to 200 h of operation per year with the maintenance intervals and procedures being carried out as prescribed by the manufacturers. The permissible average power output over 24 h of operation shall not exceed 70 % of the ESP.



+90 533 070 09 09 pbx  
info@thorgenerator.com

### THOR GENERATOR

High E Blok Daire 3106 Ünalın Mah. Libadiye Cad.

Emaar Squar Üsküdar/İstanbul/Türkiye

+90 216 759 81 29 | www.thorgenerator.com

### ENGINE

#### SPECIFICATIONS

Engine		CUMMINS
Model		6BTA5.9-G12
Number of Cylinder	L	6 cylinders - in line
Bore	mm	102
Stroke	mm	120
Displacement	lt	5,9
Aspiration		Turbo Charged and Charge Air
Compression Ratio		17.3:1
RPM	d/dk	1500
Oil Capacity (Total With Filter)	lt	16,4
Standby Power	kW/HP	155/207
Prime Power		140/187
Block Heater QTY		1
Block Heater Power	Watt	1000
Fuel Type		Diesel
Injection Type and System		Direct
Type of Fuel Pump		BYC P7100
Governor System		Electronic
Operating Voltage	VDC	24 Vdc
Battery and Capacity	Qty/Ah	2x66
Charge Alternator	A	40
Cooling Method		Water Cooled
Cooling Fan Air Flow	m <sup>3</sup> /min	333
Coolant Capacity	lt	10/32
Air filter		Dry Type
Fuel Cons. Prime With %100 Load	lt/hr	34
Fuel Cons. Prime With %75 Load	lt/hr	26
Fuel Cons. Prime With %50 Load	lt/hr	17

### ALTERNATOR

#### SPECIFICATIONS

Number Of Phases		3
Power Factor		0,8
No of Bearings		Single
No of Poles		4
No of Leads		6-12
Insulation Class		H
Degree of Protection		IP23
Excitation System		AVR

### DIMENSIONS

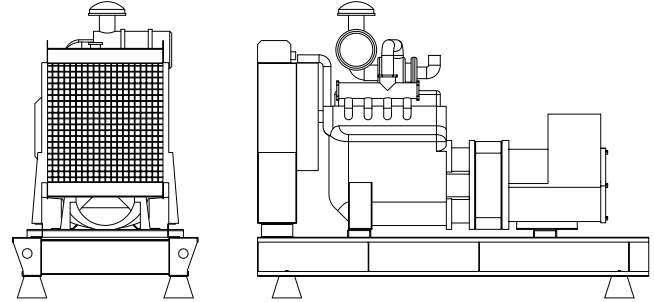

#### OPEN TYPE

WxLxH	mm	1080 x 2367 x 1731
Weight	kg	1375
Fuel Tank Capacity	lt	340

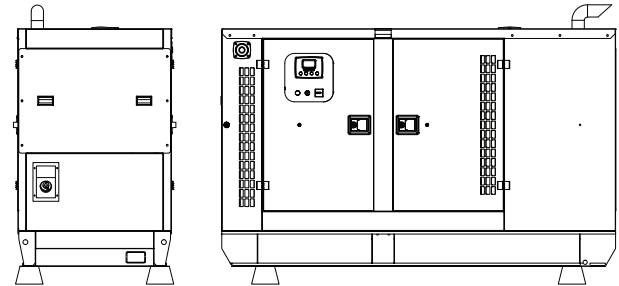

#### CANOOPED

WxLxH	mm	1147 x 3402 x 2007
Weight	kg	1880
Fuel Tank Capacity	lt	340

#### SOUNDPROOF CANOOPED

- Special design for minimizing acoustic level
- Galvanized steel construction further protected by polyester powder coat paint
- Black finish stainless steel locks and hinges
- Control panel viewing window in a lockable access door
- Emergency stop push button (red) mounted on enclosure exterior
- Lifting, drag and jacking points on base frame
- Radiator fill via removable, flush mounted rain cap fitted with compression seal



### OPTIONAL GENSET CONTROLLERS

Next generation single gen-set controllers for Stand-by and Prime power applications combining multi-functionality and wide communication with EFI engines.

Datakom SMART 200



Datakom D500



Datakom D500-GSM



EMKO Trans-AUTO



DEEPSEA 7320



ComAp AMF25



	Datakom SMART 200	Datakom D500	Datakom D500-GSM	Deepsea 6120	Deepsea 7320	ComAp AMF25	EMKO Trans-AUTO
Automatic Mains Monitoring	✓	✓	✓	✓	✓	✓	✓
Manuel Start	✓	✓	✓	✓	✓	✓	✓
Remote Start	OPTIONAL	OPTIONAL	✓	X	OPTIONAL	OPTIONAL	OPTIONAL
Remote Monitoring With Sim Card	X	OPTIONAL	OPTIONAL	OPTIONAL	OPTIONAL	OPTIONAL	OPTIONAL
1 Additional Option (Horn, Oil-Fuel Heater Etc.)	✓	✓	✓	✓	✓	✓	✓
Light Warning And Mimic Diagram	✓	✓	✓	✓	✓	✓	✓
Battery Charger	✓	✓	✓	✓	✓	✓	✓
Rs-485 Communication	OPTIONAL	✓	✓	X	✓	OPTIONAL	✓
Ethernet (Tcp-Ip) Communication	X	✓	✓	X	OPTIONAL	OPTIONAL	OPTIONAL

### OPTIONAL EQUIPMENTS

Some of our Optional Equipments which can be provided with Generator Sets But not limited to;

- Medium voltage alternator
- Remote radiator applications
- External fuel tanks. Automatic and Manuel fuel filling system from external fuel tanks
- Fuel tank heater, oil pan heater, Anti-condensation heater
- Alternator with PMG (Permanent Magnet Generator)
- Synchronization systems
- Double Walled Fuel Tanks
- Container type canopy
- Lube oil and fuel drain pumps
- Trailer
- Remote monitoring options on the control panel
- Electronic fuel level indicator

